

OWNER'S MANUAL

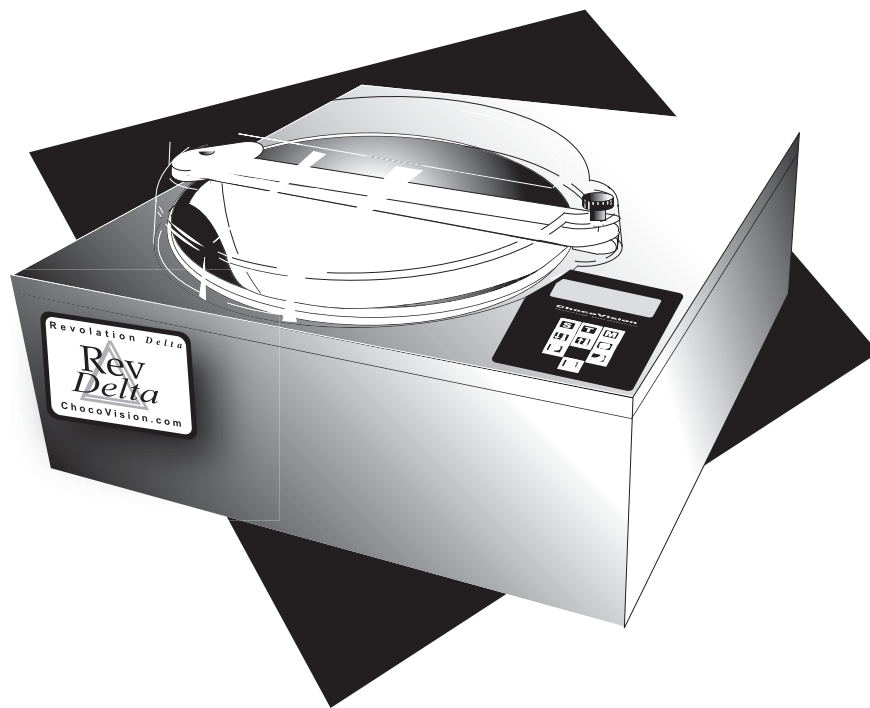

Revolution Delta CHOCOLATE TEMPERING SYSTEM

ChocoVision™
Technology MEANS PRODUCTIVITY

14 CATHARINE STREET POUGHKEEPSIE, NY 12601
TEL: (845) 473.4970 (845) 479.5453 FAX: (845) 473.8004

INTRODUCTION

ChocoVision Corp. REVOLUTION DELTA Microprocessor Controlled Chocolate Tempering Machine

FOR PROFESSIONAL/LABORATORY/COMMERCIAL USE

Thank you for purchasing the **Revolution Delta** Chocolate Tempering Machine by **ChocoVision Corp.** This unit is a fully-automatic, microprocessor-controlled system designed for professional chocolatiers, pastry chefs, caterers, restaurateurs and candy shops.

The **Revolution Delta** represents ChocoVision's latest and most sophisticated breakthrough with regard to the tempering of chocolate. It has all the existing capabilities of our best-selling **Revolution X 3210** machine, with the addition of an advanced software system and display. Created to the specifications of some of the world's most demanding pastry chefs and confectioners, the **Revolution Delta** can be fully programmed to accommodate the most precise temperature cycles. Its revolutionary *PROGRAM MODE* allows for up-to 26 specific temper cycles to be saved to memory and utilized by the chocolatier at any time. Additional features new to the **Delta** include *EXTENDED TEMPER MODE*, which keeps chocolate in perfect temper for over ten hours, *MANUAL MODE*, which allows for the processing of non-cocoa-based chocolates, and has a dynamic new temperature display (C or F). As with all ChocoVision's temperers, it can be operated in a simple, three-keystroke manner.

Built for heavy commercial use, the **Revolution Delta** can melt and temper 10 Lbs. of chocolate within about an hour and is built to last with its stainless steel casing.

The **Revolution X 3210** and **Revolution Delta** machines are available directly from ChocoVision or designated dealers.

For information about product availability contact:

sales@chocovision.com

TABLE OF CONTENTS

INTRODUCTION.....	1
TABLE OF CONTENTS.....	2
SAFETY TIPS.....	3
YOUR MACHINE (<i>EXPLODED VIEW</i>).....	4
ASSEMBLY.....	5
CONTROLS.....	6
USING YOUR MACHINE (<i>STANDARD FUNCTIONS</i>).....	7
TIPS.....	9
FREQUENTLY ASKED QUESTIONS.....	10
CLEANING.....	12

ADVANCED FUNCTIONS

ETM (<i>EXTENDED TEMPER MODE</i>).....	7
FARANHEIT / CELSIUS.....	8
OVERNIGHT MODE.....	8
HEAT CONTROLS.....	7
PROGRAMMABLE MODE.....	8
BOWL PAUSE.....	8
MANUAL MODE.....	8

IMPORTANT SAFETY TIPS

PLEASE READ AND UNDERSTAND THE
FOLLOWING SAFETY MEASURES
BEFORE USING YOUR MACHINE

- For personal safety, Appliance must always be plugged into a properly grounded electrical circuit.
- Do not cut or remove the third (ground) prong from the power plug or attempt to use a grounding adaptor.
- Never immerse the machine in water (see cleaning instructions page 11).
- Always locate the machine away from any water source. Avoid water splashing on top of or into the machine or near the fan areas.
- Never use extension cords to power the machine.
- To avoid suffocation, keep all packing material (Plastic bags and small parts) away from children.
- Position machine so that the intake and exhaust fans are not obstructed (minimum of 6" clearance). Please also be mindful of loose objects that may block air flow.
- Unplug machine from power source when not in use.
- Always unplug your machine before cleaning. Do not use spray solvents or cleaning fluids near the machine.
- To avoid electrical shock, never open the case.

YOUR MACHINE

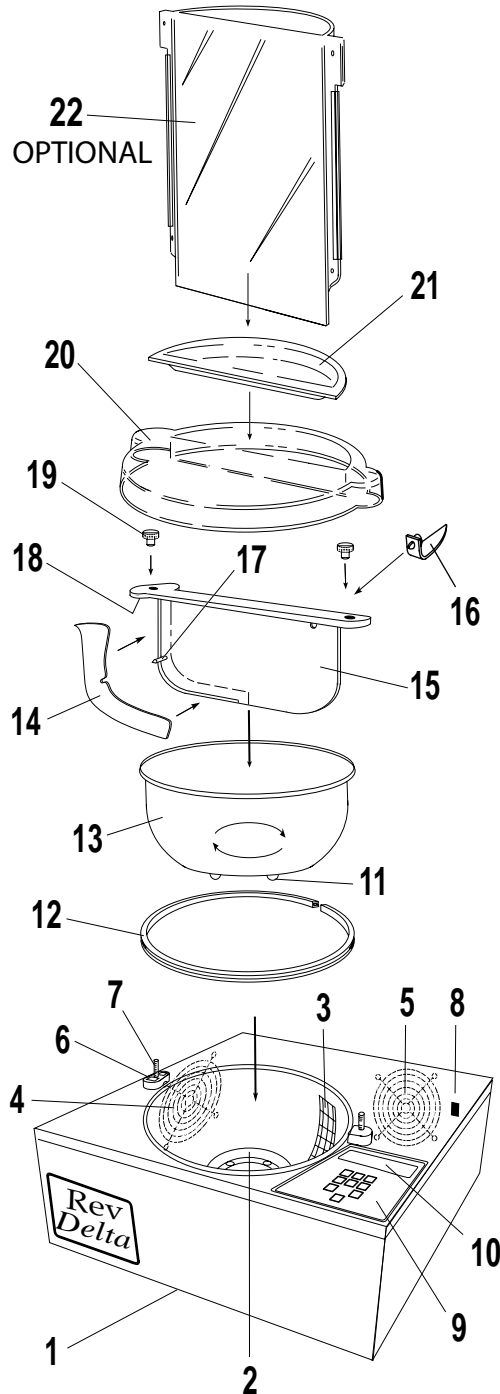

1. MAIN CASE
2. BOWL COUPLER
3. HEAT OUTLET
4. EXHAUST FAN
5. INTAKE FAN
6. PROBE CONTACTS (CASE)
7. BAFFLE MOUNTS (2)
8. POWER SWITCH
9. KEYPAD
10. DISPLAY WINDOW
11. BOWL LOCATORS
12. BOWL RING
13. BOWL
14. SCRAPER
15. BAFFLE
16. BAFFLE CLIP
17. PROBE
18. PROBE CONTACTS (BAFFLE)
19. BAFFLE KNOBS (2)
20. DUST COVER
21. DUST COVER LID
22. HOPPER (OPTIONAL)

NOTE : When using HOPPER,
DUST COVER LID cannot be used.

ASSEMBLY

BEFORE USING YOUR MACHINE, WASH ALL COMPONENTS THAT MAY COME INTO CONTACT WITH CHOCOLATE USING A SOFT SPONGE OR CLOTH AND MILD SOAP.

- Lower the BOWL into your machine and rotate it until it fits into place (Fig. 1).
- Place the SCRAPER into corresponding slot on the BAFFLE (Fig. 2). Scraper will not stay in place until entire baffle is screwed-down into position. When properly installed, the scraper should curve towards the front of the machine.
- Fit the BAFFLE into the BOWL making certain that the contact “strips” on the BAFFLE and the machine’s BAFFLE MOUNTS are aligned. Thread the BAFFLE KNOBS onto both BAFFLE MOUNTS (Fig. 3). *If the BAFFLE is not installed properly, an error message (EEE) will appear in the display window, and the machine will not start.*



Fig. 1



Fig. 2



Fig. 3

Dust Cover, Lid & Hopper Assembly (Fig.4)

- Slide the HOPPER assembly into the DUST COVER opening and load with up to 10 lbs of chocolate. Solid block chocolate is recommended for ease of use.
- All LID and HOPPER components can be disassembled for easy cleaning.

**Hopper Assembly is not included with purchase*



Fig. 4

THE CONTROLS



SELECT CHOCOLATE TYPE:

Upon machine start-up, press the "S" button to select dark, milk or white chocolate. This Button may be held down to increase the length of heated bowl pause as well.



TEMPER MODE:

After chocolate has reached its melt-point, add seed and press the "T" button to select either Quick, Normal, or Extended Temper Mode. When prompted to "remove seed," you will press this "T" button again to continue. (see page 7)



MANUAL MODE:

When the machine is in start mode, you can press "M" to manually enter the desired temperature. This feature is ideal for melting compound-coating or icing.



BOWL PAUSE:

Press this button to pause the bowl for 90 seconds. Button can be held down to increase the amount of time the bowl is paused.



PROGRAMMING MODE:

Press this button upon machine start-up to enter programming mode. You can select between recipes "A" through "Z," and specify your own dark, milk, and white chocolate settings. Continue pressing "P" to switch from "Recipe," "Temper Point," "Temper Delta," and "Melt Point." Use the up and down arrow keys to select recipe and desired temperature settings.



UP / DOWN ARROW KEYS:

Increase / decrease the desired temperature in *Melt*, *Temper*, *Manual*, and *Programming* Mode. (see page 8).



The Down Arrow Key also allows you to toggle between Fahrenheit and Centigrade upon machine start-up.

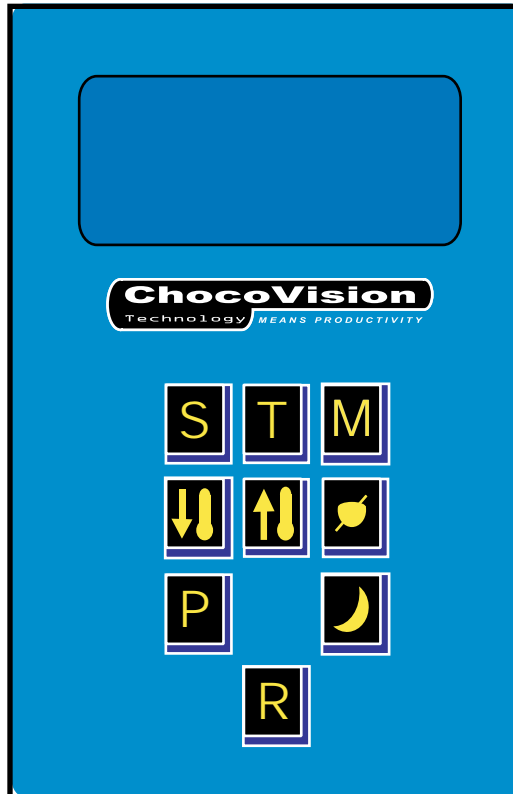

OVERNIGHT MODE:

This button can be pressed at any time to activate *Overnight Mode*, which allows your chocolate to remain in a melted state for as long as 24 hours.



RESET

Press this button any time to cancel all activities and return to the start-up state. Pressing this will not erase your stored programs.

Getting Started

- 1) Plug Machine into appropriate, grounded circuit and turn on POWER SWITCH (located in the back of the machine). Load chocolate behind the baffle. (Solid block pieces work best). You can load up to 10 lbs. of chocolate at a time if you are using the HOPPER assembly.
- 2) Press "S" to select chocolate type among DARK, MILK, or WHITE chocolate. The machine will heat the bowl for a few minutes and begin to rotate when the microprocessor determines that the chocolate has reached roughly 85°F.
- 3) After the bowl begins rotating, the chocolate will heat-up until the desired melting point (defaulted at 108°F). As the chocolate begins to melt, it will collect in a pool in front of the SCRAPER and cover the PROBE. Depending upon the room conditions, it will take approximately 45 minutes to melt 10 lbs. of chocolate.
- 4) When machine indicates (three beeps) that your chocolate has reached its desired melt-point, and is ready to be tempered, press the "T" button to select between *Quick*, *Normal* and *Extended* Tempering Modes (see below).

QUICK TEMPER: Similar to "Temper 1" on the Revolution 1, 2 and X3210 models. Chocolate will cool down directly to the desired temper point.

NORMAL TEMPER: Also called "traditional tempering," and similar to "Temper 2" on the Revolution 1, 2 and X3210 models. Chocolate temperature will fall slightly below the temper point, then come back up to the temper point (this margin is known as the "Delta").

EXTENDED TEMPER MODE (ETM): This function allows chocolate to remain in perfect temper in the bowl for extended periods of time (up to 12 hours).

Preset Melt Point: 108F

Preset Temper Points:

Milk Chocolate: 86°F

Dark Chocolate: 88.7°



White Chocolate: 87.6°F

- 5) When you select your temper mode, place at least 224 grams (8 oz) of solid, tempered chocolate ('Seed') behind the baffle, per 10 lb. batch. The machine will start cooling down, which will take around 10-15 minutes, depending on the room conditions.

- 6) Once the machine cools down and nears the temper set point, the REMOVE SEED auto alert signal will sound. Remove any remaining solid seed chocolate from behind the baffle and press the "T" button to acknowledge.

- 7) When the final stages of tempering are complete, the machine will sound three long beeps and the display will show "READY", meaning your chocolate is in temper.

NOTE: If the chocolate you are using requires higher melt or temper points, the Custom Heat Setting can circumvent the factory defaults.

While in the desired mode (MELT or TEMPER), press the UP ARROW  or the DOWN ARROW  button. Incremental numeric selections can be made with each keystroke or a rapid scroll with the button pressed.

Desired temperature change is displayed below the temperature bar.



Advanced Functions

Fahrenheit / Celsius

Each stroke of the  ARROW DOWN button toggles digital display between Fahrenheit and Celsius.



Bowl Pause

This function allows the user to quickly pause the bowl rotation for a period of 90 seconds while in the TEMPER MODE.

Press the  PAUSE button. The bowl rotation stops and countdown begins. Bowl resumes spinning when either the 90 second countdown is complete, or when the  PAUSE button is pressed again.



OVERNIGHT MODE

This feature was developed for users that would like to leave melted chocolate in the machine overnight, saving on additional melting and cleanup time.

- 1) This function can be activated at any time by pressing the  OVERNIGHT button. The machine goes through a series of bowl pauses and temperature swings. Note: The chocolate is NOT kept in temper in Overnight Mode! You must go through the tempering process detailed on page 7 after machine has been in Overnight mode.
- 2) To deactivate the OVERNIGHT MODE press the  RESET button.

PROGRAMMING MODE



This allows the user to save custom temper temperatures for each chocolate type for "special blend" recipes or to simply choose your own melting, delta, or temper set point. Once the desired temperature is set it can be recalled at a later time over and over.

- 1) To enter Programming Mode, press the "P" button while machine is in its start-up state.
- 2) Select a recipe "A" through "Z" (or DARK, MILK, or WHITE) using the  UP and  DOWN ARROW buttons.
- 3) Advance to the other menu items (TEMPER POINT, TEMPER DELTA and MELT POINT) by pressing the "P" button.
- 4) Use the UP and DOWN ARROW buttons to adjust the desired temperature settings for TEMPER POINT, TEMPER DELTA and MELT POINT.
- 5) To run a recipe, remain in Programming Mode and select the desired recipe using the UP and DOWN ARROW buttons. Press the "S" button to execute that recipe and follow tempering instructions on page 7.
- 5) Hit the RESET button at any time to save changes and exit Programming Mode.

Note: There are also recipes for "DARK", "MILK", and "WHITE" chocolates. Changing the temperature settings in programming mode for these recipes WILL change the machine defaults.

MANUAL MODE

MANUAL MODE allows a user to set a desired temperature, and the machine will simply heat up or cool down until that temperature is reached.

- 1) To enter Manual Mode, press the "M" button while machine is in its start-up state.
- 2) Use the  UP and  DOWN ARROW buttons to select desired temperature. Hold the buttons down for fast scrolling.

HINTS & TIPS

- Place your machine away from any water source where splashing can occur, getting water on or into unit. **NEVER ALLOW WATER TO MIX WITH CHOCOLATE.** Contact with water can cause chocolate to seize, rendering it unable to be re-tempered.
- Contact strips on baffle as well as corresponding contact “riser” strips on your machine should at all times be free of chocolate or any other debris, if not, your machine may have difficulty starting or working properly.
- Baffle scraper will not be in place for use until the baffle knobs are screwed-down into position with the baffle in place. When properly installed, the scraper blade will bend forward toward the front of your machine (the side with the temperature probe). See Figure 3 on page 5.
- Do not allow the level of chocolate in the machine to drop below the thermister/probe (silver “bump”) on the baffle. This probe measures the the temperature of the chocolate and reports it to the microprocessor. If the chocolate falls below this point during use, chocolate may be usable for a few minutes. You should then replenish bowl with more chocolate, press Reset, and begin the melting process again.
- Avoid placing machine directly under or next to an air conditioning vent which can create uneven heat distribution and lead to bloom.
- It is recommended to utilize the lid and cover assembly at all times other than when in temper mode (cooling) or using the chocolate. Lid and cover assembly are helpful in expediting the melting process, keeping debris out of the chocolate and maintaining consistant temper.

1. What is “pure” chocolate? What is “compound” chocolate?

“**Pure**,” unsweetened chocolate is produced from the seed of the tropical cacao tree, and contains primarily cocoa solids and cocoa butter in varying proportions. Most consumed chocolate is sweetened with sugar. Milk chocolate contains sugar and some form of either condensed or powdered milk. “White chocolate” contains cocoa butter, sugar and milk but no cocoa solids (thus is not truly chocolate).

Compound chocolate is a chocolate replacement made from a combination of cocoa, vegetable fats, coconut or palm kernel oils and sweeteners. Compound chocolate is designed to simulate enrobed chocolate on a product.

2. Why do I have to temper my chocolate?

Cocoa butter is the fat in cacao that gives chocolate its stable properties. To be considered “real” chocolate, a chocolate bar or chunk can contain only cocoa butter, not any other fat. Cocoa butter is the reason that chocolate must be tempered.

Cocoa butter is comprised of three to four fatty acids, each of which solidifies at a different temperature. When chocolate is melted, the crystals of fatty acids separate. The objective of tempering is to entice those separated fat crystals of cocoa butter back into a stable form.

Proper tempering gives chocolate a smooth and glossy finish, has a crisp snap, and won't melt as easily as untempered chocolate to the touch.

3. What is seed chocolate?

The “seed” is tempered chocolate (chunks or wafers) that should be set aside and placed behind the baffle at the beginning of the temper cycle (your machine will beep three times to indicate that your chocolate had hit its melt-point and is ready for tempering/seeding). These pieces of seed chocolate act like magnets, attracting other loose crystals of fatty acids together, beginning the crystalization process that results in a proper temper.

Tempered chocolate melts at a much higher temperature than untempered. The fat crystals are locked together tightly and are resistant to developing **chocolate bloom**.

4. What is bloom?

Chocolate bloom is visible by white-ish-gray streaks or spots on the surface of the chocolate, typically caused by two things; moisture (sugar bloom) or warmth (fat bloom).

Sugar bloom is caused by moisture which makes the sugar in chocolate dissolve. Once the moisture evaporates, sugar crystals remain on the surface. Your chocolate will become sticky and discolored. Although sugar bloom is most often the result of humid storage, it can occur when stored in a cool climate and moved too quickly to a warmer one.

Fat bloom is similar to sugar bloom, except that it is fat or cocoa butter separating from the chocolate and depositing itself outside of it. As with sugar bloom, the most common causes of fat bloom are quick temperature changes and overly warm storage.

5. *How does climate affect chocolate tempering?*

If your work area is overly hot or cold, there is a good chance that it will have a negative effect on your finished chocolate products. As stated, relative room humidity can cause or make your chocolate susceptible to sugar bloom. A room that is either too hot, cold or humid will interfere with your chocolate setting-up properly.

Ideal working conditions are:

- 66-70° Fahrenheit OR 18.5-21° Celsius
- Humidity below 50%

6. *How does the storage of my raw chocolate affect tempering?*

Your chocolate can come out of temper if not stored properly. Ideally, chocolate should be wrapped thoroughly to avoid moisture and stored at a constant temperature of 55° to 60°F with a relative humidity at or below 50% (neither temperature or humidity varying much). Chocolate has a propensity to absorb odor very quickly, so do not store your chocolate within the vicinity of any items that exude a pungent odor.

Stored under perfect conditions, unsweetened and dark chocolate will last for up to 18 months, milk and white chocolate for 8 to 12 months.

7. *Why may my chocolate have thickened?*

Due to constant bowl rotation and agitation of the chocolate, the viscosity will increase. A typical 10 Lb. batch of (dark) chocolate, depending on room conditions, will stay in perfect temper for between 45 to 90 minutes. Thickening is a sign of overseeding, overtempering, or overcrystallization.

As stated, the nature of the machine dictates roughly an hour of optimum dipping time before overtempering begins. That said, there are measures to prolong your window of dipping by heading the following:

- Remove all seed chocolate when instructed.
- Only dip items that are at room temperature.
- Use your chocolate within 1 to 1.5 hours.
- Raise the temperature incrementally as you notice chocolate thickening (Do not exceed 92° F)
- Add cocoa butter as you notice chocolate thickening (consult with a professional).

CLEANING YOUR MACHINE

- Always unplug your machine before cleaning. Never use spray solvents or cleaning fluids near the machine.
- When machine is done for the day, the outside, metal case should be wiped-down with a wet rag or sponge with a mild soap. NEVER use steel wool or any other type of abrasive to clean your machine or any of its components.
- Use the special baffle cleaning brush for areas where chocolate collects and may be difficult to clean, such as the inside of the bowl ring and crevices on the baffle.